

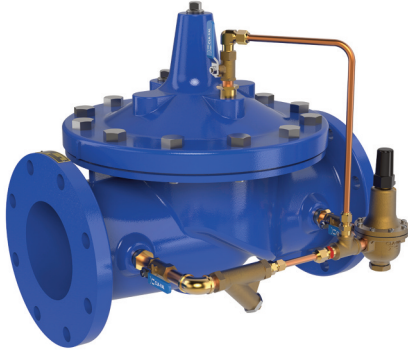

MODEL 90-01KO

Anti-Cavitation Pressure Reducing Valve



- Virtually Cavitation Free Operation
- Sensitive and Accurate Pressure Control
- Easy Adjustment and Maintenance
- Optional Check Feature
- Fully Supported Frictionless Diaphragm

The Cla-Val Model 90-01KO Anti-Cavitation Hytrol Pressure Reducing Valve automatically reduces a higher inlet pressure to a steady lower downstream pressure, regardless of changing flow rate and/or varying inlet pressure. This valve is an accurate, pilot-operated regulator capable of holding downstream pressure to a pre-determined limit. When downstream pressure exceeds the pressure setting of the control pilot, the main valve and pilot valve close drip-tight.

If a check feature is added, and a pressure reversal occurs, the downstream pressure is admitted in the main valve cover chamber, closing the valve to prevent return flow.

Schematic Diagram

Item	Description
1	100-01KO Hytrol Main Valve
2	X58 Restriction Fitting
3	CRD Pressure Reducing Control

Optional Features

Item	Description
A	X46A Flow Clean Strainer
B	CK2 Isolation Valve
C	CV Flow Control (Closing)*
D	Check Valves with Isolation Valve
P	X141 Pressure Gauge
S	CV Speed Control (Opening)
V	X101 Valve Position Indicator
Y	X43 "Y" Strainer
H	X43H Strainer

*The closing speed control (optional) on this valve should always be open at least three (3) turns off its seat.

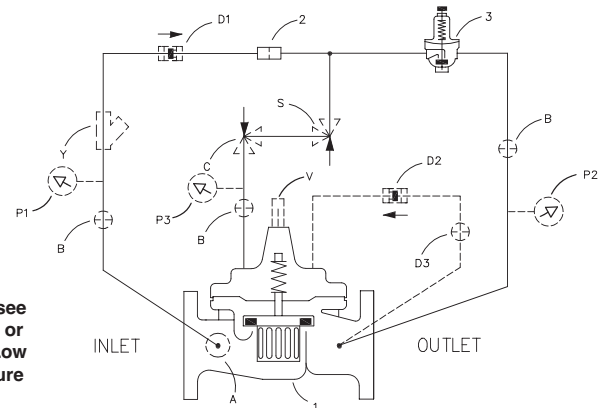

For space savings, see Cla-Val Model 90-48 or 90-99 with integral Low Flow Bypass Pressure Regulator.

Typical Applications

Typical applications include pressure reducing valve station using Model 90-01BYKO and Model 90-01ASKO in parallel to handle wide range of flow rates. Larger valve meets requirements of peak loads. The smaller valve handles low flows. A downstream pressure relief valve is recommended for this type of application.

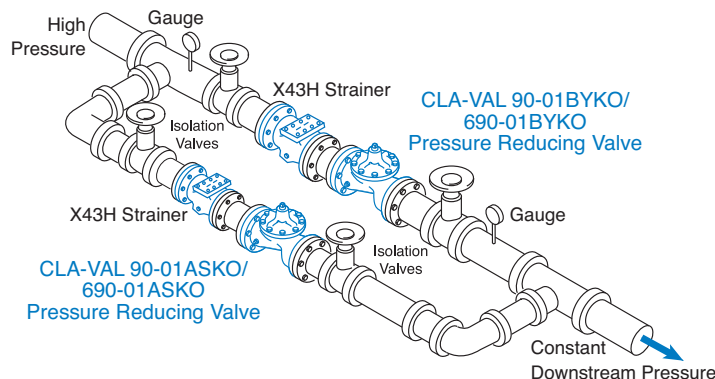

Cla-Val Model 90-01KO provides optimum downstream pressure control while reducing noise and eliminating damage associated with cavitation. See Cavitation Guide to determine if the valve is a candidate for the KO Anti-Cavitation Trim. A downstream pressure relief valve is recommended for this type of application.

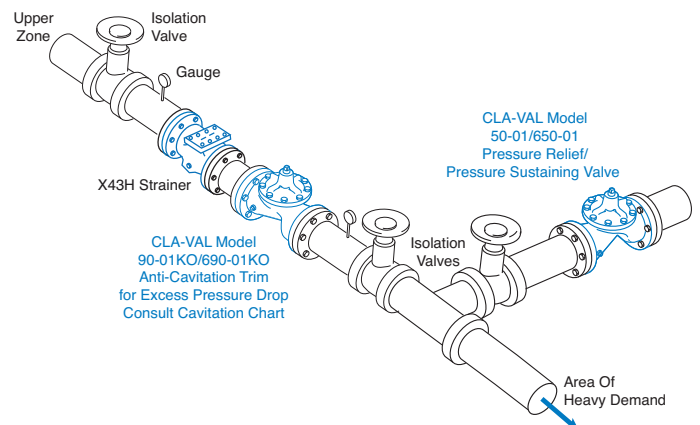

Model 90-01KO (Uses 100-01KO Hytrol Main Valve)

Operating Temp. Range

Pattern	Globe	Angle	Grooved End
Size	25 - 900mm	32 - 400 & 600	32 - 200mm

Fluids
-40° to 82° C

Pressure Ratings (Recommended Maximum Pressure - psi)

Valve Body & Cover		Pressure Class				
		Flanged			Grooved	Threaded
Grade	Material	ANSI Standards*	150 Class	300 Class	300 Class	End‡ Details
ASTM A536	Ductile Iron	B16.42	250	400	400	400
ASTM A216-WCB	Cast Steel	B16.5	285	400	400	400
UNS 87850	Bronze	B16.24	225	400	400	400

Note: * ANSI standards are for flange dimensions only.
 Flanged valves are available faced but not drilled.
 ‡ End Details machined to ANSI B2.1 specifications.
Valves for higher pressure are available; consult factory for details

Materials

Component	Standard Material Combinations		
Body & Cover	Ductile Iron	Cast Steel	Bronze
100-01KO Available Sizes	25 - 900mm	8" - 400mm	80 - 400mm
Disc Retainer & Diaphragm Washer	Cast Iron	Cast Steel	Bronze
Trim: Disc Guide, Seat & Cover Bearing	Stainless Steel is Standard		
Disc	Buna-N® Rubber		
Diaphragm	Nylon Reinforced Buna-N® Rubber		
Stem, Nut & Spring	Stainless Steel		

For material options not listed, consult factory.
 Cla-Val manufactures valves in more than 50 different alloys.

100G-01KO ANTI-CAVITATION VALVE CURVES

SOLID LINE IS FULL OPEN FLOW CURVES FOR 5.5 L/S CONTINUOUS DUTY APPLICATIONS
 DASHED LINE IS FULL OPEN FLOW CURVE FOR 7.6 L/S INTERMITTENT DUTY APPLICATIONS

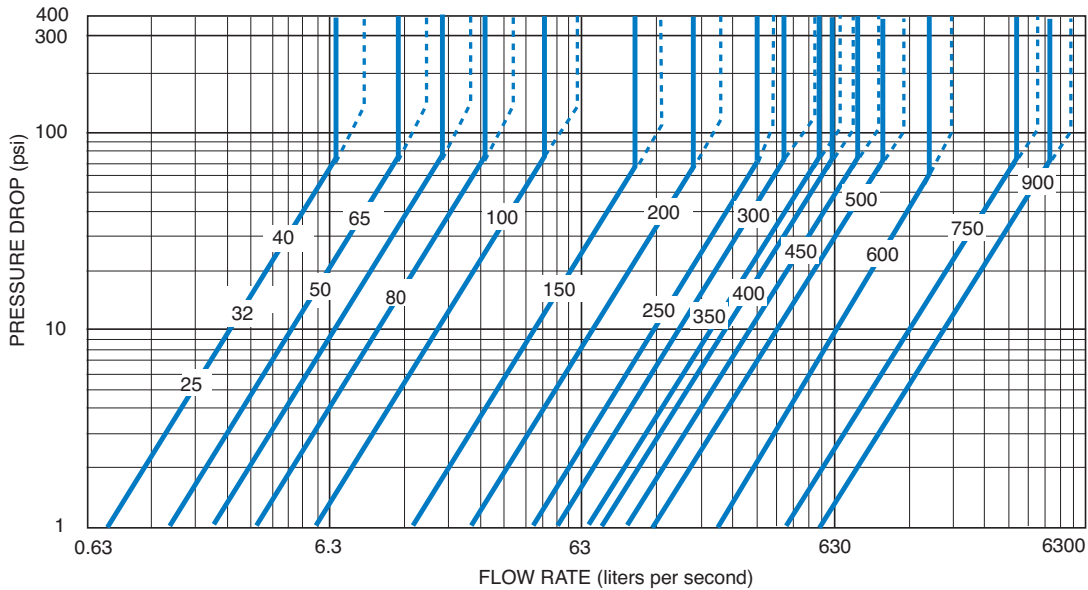

Notes: On Operating Differential

1. For atmospheric discharge, the maximum inlet pressure cannot exceed 150 psi.
2. For pressure differentials greater than 300 psi, the maximum flow velocity should not exceed 18 ft/sec.
3. Flow velocities greater than 25 ft/sec are not recommended.
4. Recommended minimum flow velocity is 1 ft/sec.
5. Consult factory for conditions exceeding these recommendations.

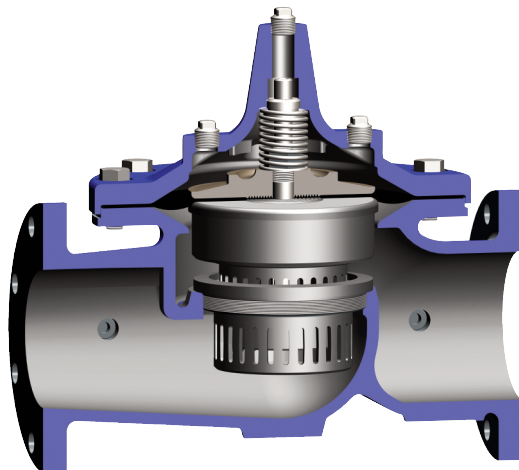

100-01KO Hytrol Main Valve

SELECTION GUIDELINE FOR KO ANTI-CAVITATION VALVES

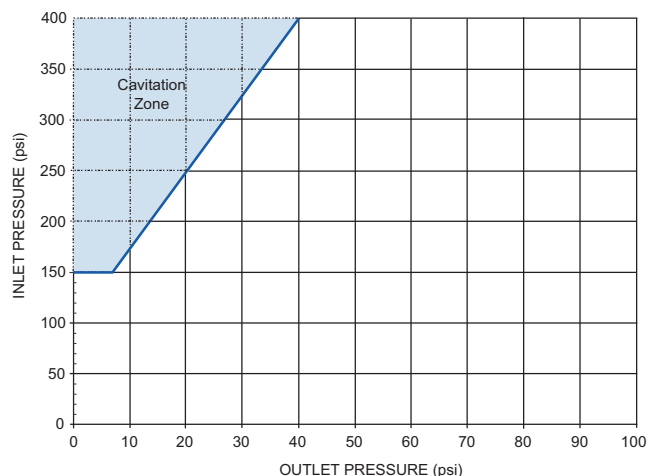

Model 90-01KO Dimensions (Uses 100-01KO Hytrol Main Valve)

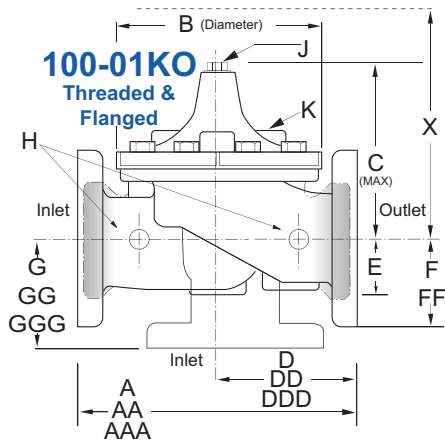

Model 100-01KO Full Port Hytrol Main Valve

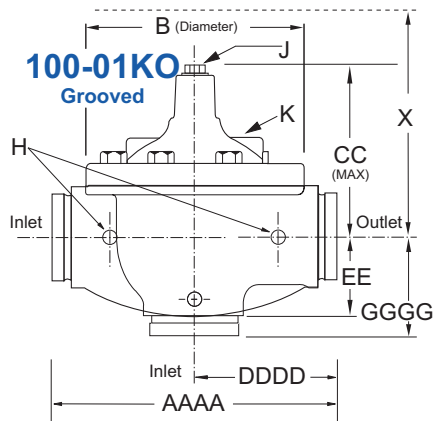

Note:
Consult Factory on 10", 12",
16" angle pattern

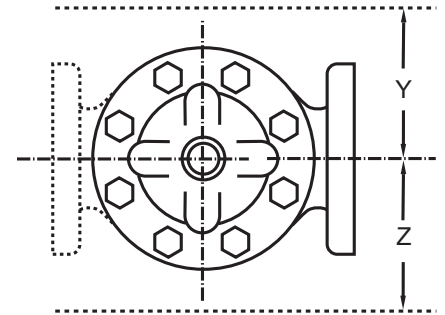

Model 90-01KO Dimensions (In mm)

Valve Size (mm)	25	32	40	50	65	80	100	150	200	250	300	350	400	450	500	600	750	900
A Threaded	184	184	184	238	279	318	—	—	—	—	—	—	—	—	—	—	—	—
AA 150 ANSI	—	—	216	238	279	305	381	508	645	756	864	991	1051	1168	1321	1562	1600	1848
AAA 300 ANSI	—	—	229	254	295	337	397	533	670	790	902	1029	1105	1210	1326	1606	1638	1899
AAAA Grooved End	—	—	216	228	279	318	381	508	645	—	—	—	—	—	—	—	—	—
B Diameter	143	143	143	168	203	232	292	400	508	600	711	832	902	1054	1143	1350	1422	1676
C Maximum	140	140	140	165	192	208	270	340	406	435	530	614	635	992	1064	1116	1387	1499
CC Maximum Grooved End	—	—	120	146	175	184	236	308	371	—	—	—	—	—	—	—	—	—
D Threaded	83	83	83	121	140	159	—	—	—	—	—	—	—	—	—	—	—	—
DD 150 ANSI	—	—	102	121	140	152	191	254	322	378	432	495	528	—	—	781	—	—
DDD 300 ANSI	—	—	108	127	149	162	200	267	337	395	451	514	549	—	—	803	—	—
DDDD Grooved End	—	—	—	121	—	152	191	—	—	—	—	—	—	—	—	—	—	—
E	29	29	29	38	43	52	81	110	135	235	273	321	394	329	381	451	541	624
EE Grooved End	—	—	52	64	73	79	108	152	192	—	—	—	—	—	—	—	—	—
F 150 ANSI	—	—	64	76	89	95	114	140	171	203	241	267	298	381	419	489	572	724
FF 300 ANSI	—	—	78	83	95	105	127	159	191	222	260	292	324	381	419	489	610	762
G Threaded	48	48	48	83	102	114	—	—	—	—	—	—	—	—	—	—	—	—
GG 150 ANSI	—	—	102	83	102	102	127	152	203	219	349	378	399	—	—	560	—	—
GGG 300 ANSI	—	—	102	89	110	111	135	165	216	236	368	397	419	—	—	582	—	—
GGGG Grooved End	—	—	—	83	—	108	127	—	—	—	—	—	—	—	—	—	—	—
H NPT Body Tapping	0.375	0.375	0.375	0.375	0.50	0.50	0.75	0.75	1.00	1.00	1.00	1.00	1.00	1.00	1.00	1.00	2.00	2.00
J NPT Cover Center Plug	0.25	0.25	0.25	0.50	0.50	0.50	0.75	0.75	1.00	1.00	1.25	1.50	2.00	1.00	1.00	1.00	2.00	2.00
K NPT Cover Tapping	0.375	0.375	0.375	0.375	0.50	0.50	0.75	0.75	1.00	1.00	1.00	1.00	1.00	1.00	1.00	1.00	2.00	2.00
Stem Travel	10	10	10	15	18	20	28	43	58	71	86	102	114	130	143	171	190	216
Approx. Ship Weight (kgs)	7	7	7	16	23	32	64	129	227	354	528	726	1027	1353	1769	2812	3494	5316
Approx. X Pilot System	280	280	280	331	356	381	432	737	788	839	915	1016	1016	1093	1194	1728	2007	2159
Approx. Y Pilot System	229	229	229	229	254	280	305	508	559	610	661	737	762	813	864	991	1016	1143
Approx. Z Pilot System	229	229	229	229	254	280	305	508	559	610	661	737	762	813	864	991	1067	1194

Cla-Val Control Valves with KO ANTI-CAVITATION Trim operate with maximum efficiency when mounted in horizontal piping with the main valve cover Up. We recommend isolation valves be installed on inlet and outlet for maintenance. Adequate space above and around the valve for service personnel should be considered essential. A regular maintenance program should be established based on the specific application data. However, we recommend a thorough inspection be done at least once a year. Consult factory for specific recommendations.

90-01KO Valve Selection		100-01KO Pattern: Globe (G), Angle (A), End Connections: Threaded (T), Grooved (GR), Flanged (F) Indicate Available Sizes																			
		Inches	1	1¼	1½	2	2½	3	4	6	8	10	12	14	16	18	20	24	30	36	
		mm	25	32	40	50	65	80	100	150	200	250	300	350	400	450	500	600	750	900	
Main Valve 100-01KO		Pattern	G	G, A	G, A	G, A	G, A	G, A	G, A	G, A	G, A	G, A	G, A	G, A	G	G	G, A	G	G		
		End Detail	T	T	T, F, Gr*	T, F, Gr	T, F, Gr*	T, F, Gr	F, Gr	F, Gr*	F, Gr*	F	F	F	F	F	F	F	F	F	
Suggested Flow (gpm)		Max. Continuous	84	84	115	190	270	410	710	1620	2810	4420	6280	7590	9920	12550	14900	22600	37700	52450	
		Max. Intermittent	120	120	160	260	370	580	990	2250	3900	6150	8720	10540	13700	17500	21700	31300	48000	62500	
		Min. Continuous	10	10	10	15	20	30	50	115	200	300	400	500	650	560	1073	1577	2650	3150	
Suggested Flow (Liters/Sec)		Max. Continuous	5	5	7	12	17	26	45	102	177	279	396	479	626	792	940	1426	2379	3309	
		Max. Intermittent	7.6	7.6	10	16	23	37	62	142	246	387	549	664	863	1104	1369	1972	3028	3940	
		Min. Continuous	.6	.6	.6	.9	1.3	1.9	3.2	7.2	13	19	25	32	41	41	57	110	132	180	
100-01KO Series is the full internal port Hytrol.										For Lower Flows Consult Factory										*Globe Grooved Only	

Functional Data

Valve Size		Inches	1	1¼	1½	2	2½	3	4	6	8	10	12	14	16	18	20	24	30	36
		mm.	25	32	40	50	65	80	100	150	200	250	300	350	400	450	500	600	750	900
C _v Factor	Globe Pattern	Gal./Min. (gpm.)	14	14	14	25	37	52	90	218	362	660	810	1100	1200	1550	1950	3900	6100	9150
		Litres/Sec. (l/s.)	3.4	3.4	3.4	6.0	8.9	12.5	21.6	52	87	159	194	264	288	360	469	938	1466	2199
	Angle Pattern	Gal./Min. (gpm.)	—	15	15	26	39	55	95	232	388	479	790	1075	1175	—	—	—	—	—
		Litres/Sec. (l/s.)	—	3.6	3.6	6.2	9.4	13.2	22.8	56	93	115	190	258	282	—	—	—	—	—
Equivalent Length of Pipe	Globe Pattern	Feet (ft.)	196	196	196	237	277	416	572	858	1315	2444	2118	1937	3022	3537	4199	4532	3897	3954
		Meters (m.)	60	60	60	72	84	127	174	262	401	745	646	590	921	1078	1280	1381	1188	1205
	Angle Pattern	Feet (ft.)	—	171	171	219	250	372	514	757	1145	2133	2226	2021	3152	—	—	—	—	—
		Meters (m.)	—	52	52	67	76	113	157	231	349	650	678	616	961	—	—	—	—	—
K Factor	Globe Pattern	30.6	30.6	30.6	26.1	24.3	29.3	29.0	25.5	27.7	41.0	27.7	22.8	31.4	30.2	29.5	28.9	17.6	15.1	
	Angle Pattern	—	26.7	26.7	24.1	21.8	26.2	26.0	22.5	24.1	35.8	29.1	23.8	32.8	—	—	—	—	—	
Liquid Displaced from Cover Chamber When Valve Opens	U.S. Gal.	0.2	0.2	0.2	.03	.04	.08	.17	.53	1.26	2.5	4.0	6.5	9.6	11	12	29	65	90	
	Litres	0.8	0.8	0.8	.12	.16	.30	.64	2.0	4.8	9.5	15.1	25.6	36.2	41.6	45.4	110	246	340	

For assistance in selecting appropriate valve options or valves manufactured with special design requirements, please contact our Regional Sales Office or Factory.

C_v Factor

Formulas for computing C_v Factor, Flow (Q) and Pressure Drop (ΔP):

$$C_v = \frac{Q}{\sqrt{\Delta P}} \quad Q = C_v \sqrt{\Delta P} \quad \Delta P = \left(\frac{Q}{C_v} \right)^2$$

K Factor (Resistance Coefficient)

The Value of K is calculated from the formula: $K = \frac{894d^4}{C_v^2}$ (U.S. system units)

Equivalent Length of Pipe

Equivalent lengths of pipe (L) are determined from the formula: $L = \frac{Kd}{12f}$ (U.S. system units)

Fluid Velocity

Fluid velocity can be calculated from the following formula: $V = \frac{.4085 Q}{d^2}$ (U.S. system units)

Where:

C_v = U.S. (gpm) @ 1 psi differential at 60° F water or

= (l/s) @ 1 bar (14.5 PSIG) differential at 15° C water

d = inside pipe diameter of Schedule 40 Steel Pipe (inches)

f = friction factor for clean, new Schedule 40 pipe (dimensionless) (from Cameron Hydraulic Data, 18th Edition, P 3-119)

K = Resistance Coefficient (calculated)

L = Equivalent Length of Pipe (feet)

Q = Flow Rate in U.S. (gpm) or (l/s)

V = Fluid Velocity (feet per second) or (meters per second)

ΔP = Pressure Drop in (psi) or (bar)

Pilot System Specifications

Adjustment Ranges

- 2 to 30 psi
- 15 to 75 psi
- 20 to 105 psi
- 30 to 300 psi*

*Supplied unless otherwise specified

Other ranges available, please consult factory

Temperature Range

Water: to 82°C

Materials

Standard Pilot System Materials

Pilot Control: Low Lead Bronze

Trim: Stainless Steel Type 303

Rubber: Buna-N® Synthetic Rubber

Tubing & Fitting: Cooper and Bronze

Optional Pilot System Materials

Pilot Systems are available with optional Aluminum, Stainless Steel or Monel materials.

Note: Available with remote sensing control.

When Ordering, Specify:

1. Catalog No. 90-01KO
2. Valve Size
3. Pattern - Globe or Angle
4. Pressure Class
5. Threaded, Flanged or Grooved End
6. Trim Material
7. Adjustment Range
8. Desired Options
9. When Vertically Installed