

CLASS 150 CAST BRONZE SCREWD END GATE VALVES

INSIED SCREW,RISING STEM,SCREWED BONNET

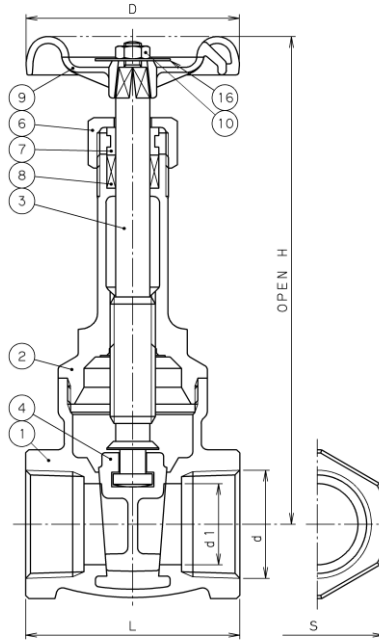

Materials

No.	Name of parts	ASTM Specifications		
1	BODY	CAST BRONZE	B62-C83600	
2	BONNET	CAST BRONZE	B62-C83600	
3	STEM	CAST BRONZE	B62-C83600	
4	DISC	CAST BRONZE	B62-C83600	
6	PACKING NUT	FORGED BASS	B283-C37700	
7	GLAND	BRASS ROD	B16	
8	GLAND PACKING	ARAMID FIBERS GRAPHITE		
9	HAND WHEEL	ALUMINUM DIE-CAST	B85	
10	WHEEL NUT	BRASS ROD	B16	
16	NAME PLATE	ALUMINUM		

Dimensions

Mark	Size	1/2	3/4	1	1 1/4	1 1/2	2
d	NPT 1/2	NPT 1/2	NPT 3/4	NPT 1	NPT 1 1/4	NPT 1 1/2	NPT 2
	mm.	15	20	25	32	40	50
G	mm.	137	157	180	216	257	296
H	mm.	51	56	66	68	74	84
L	mm.	55	70	70	80	90	100
D	mm.	28	34	41	52	57	70
Weight	kgs.	0.42	0.64	0.94	1.66	1.83	2.72

Working Pressures

Working pressures Non-Shock	
Saturated steam pressure	Water,Oil,Gas
1.03MPa	2.07MPa
150psi	300psi

*Design and materials are subject to change without notice.

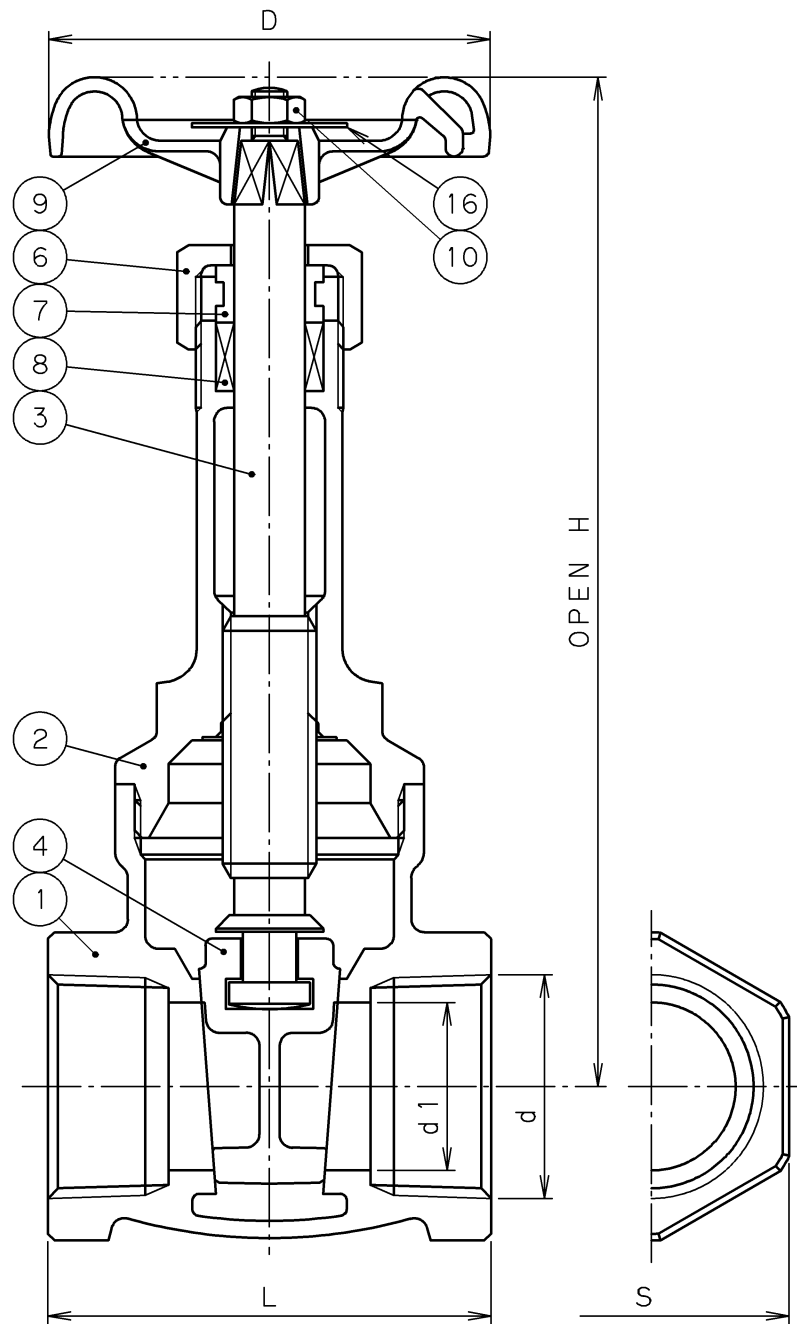

DIMENSIONS UNIT: mm

SIZE		d	d1	H	L	D	S	MASS (Kg)	Q'ty
A	B								
15	1/2	NPT 1/2	15	137	51	55	28	0.42	
20	3/4	NPT 3/4	20	157	56	70	34	0.64	
25	1	NPT 1	25	180	66	70	41	0.94	
32	1 1/4	NPT 1 1/4	32	216	68	80	52	1.66	
40	1 1/2	NPT 1 1/2	40	257	74	90	57	1.83	
50	2	NPT 2	50	296	84	100	70	2.72	

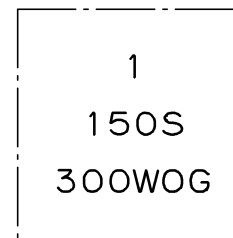
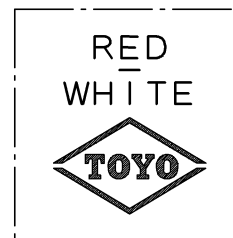

BODY MARKING

16	NAME PLATE	ALUMINUM	
10	WHEEL NUT	BRASS ROD	B16
9	HAND WHEEL	ALUMINUM DIE-CAST	B85
8	GLAND PACKING	ARAMID FIBERS GRAPHITE	
7	GLAND	BRASS ROD	B16
6	PACKING NUT	FORGED BRASS	B283-C37700
4	DISC	CAST BRONZE	B62-C83600
3	STEM	CAST BRONZE	B62-C83600
2	BONNET	CAST BRONZE	B62-C83600
1	BODY	CAST BRONZE	B62-C83600

No.	PART	MATERIAL (ASTM)
-----	------	-----------------

FACE TO FACE OR END TO END
MAKER'S STANDARD

END CONNECTION
ASME B1.20.1

WALL THICKNESS
MAKER'S STANDARD

PRESSURE TEST
MAKER'S STANDARD

CLASS 150
CAST BRONZE
SCREWED END GATE VALVE
INSIDED SCREW, RISING STEM,
SCREWED BONNET

APP'D	K. Kobayashi	FIGURE	PRODUCT CODE
CHK'D	H. Fuseya	150-BSR-N NPT	209
CHK'D	M. Mochizuki	DRAWING No.	△
PREP'D	K. Kohama	T1210S008 △	△
DATE	JUL. 31. '15	MARK	DATE BY



Toyo Valve Co., Ltd.